

Electric Cylinder Actuator

Contents

[Overview](#)

[Applications](#)

[Technical Specifications](#)

[Assembly Instructions](#)

[Configuration and position sensors setup](#)

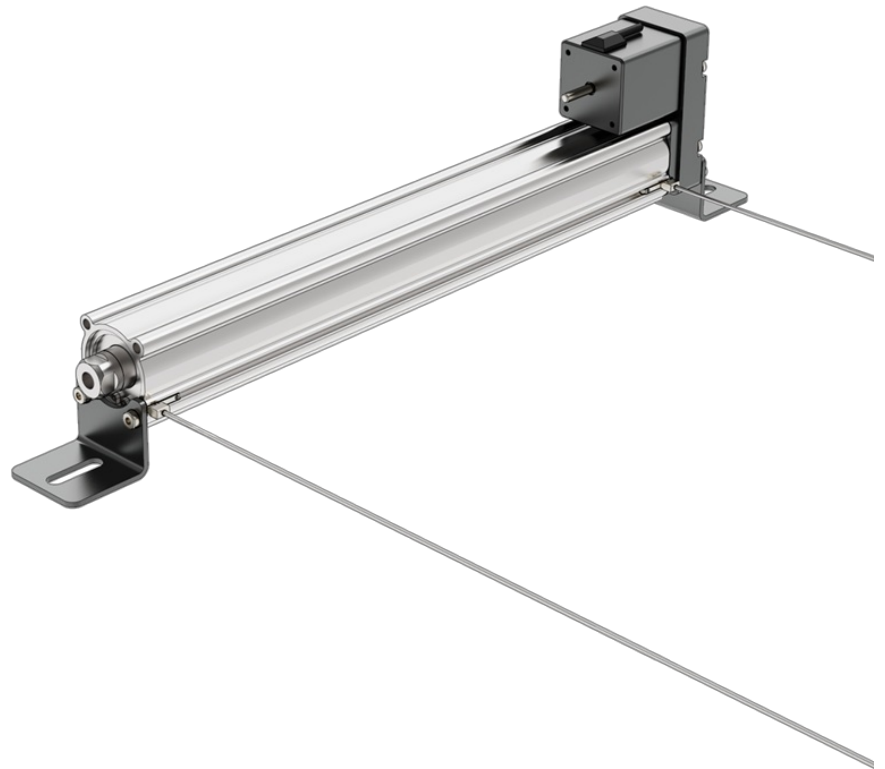

Overview

The [electric cylinder actuator](#) is a fully enclosed actuator based on a leadscrew mechanism. When the NEMA 17 motor rotates, the motion is transferred through the mechanism and converted to linear motion by the leadscrew which causes the protruding shaft to move in and out of the front face depending on the motor rotation direction. The use of a stepper motor allows for easy plug-and-play with the Vention MachineMotion 2 controller and offers complete position, speed, and acceleration control.

Applications

Electric cylinders have a wide range of applications, from pneumatic or hydraulic actuator replacement for those who do not want to run a pneumatic or hydraulic system, to high precision positioning systems. Check out our public library for inspirations on how to integrate an electric cylinder within your design!

[Browse Open Source Designs](#)

Technical Specifications

The electric cylinders are available in 3 lengths: [100mm stroke](#), [250mm stroke](#), and [400mm stroke](#). All 3 actuators are powered by the same NEMA 17 motor and they all share the same lead pitch. For this reason, the data shown below is common to all three models, with the stroke length being the only variable. Each actuator also includes two pre-installed reed switches that are wired to an M12 4-pin connector and act as either a home or end of travel sensor.

MO-EC-001-0100__2

MO-EC-001-0250__2

MO-EC-001-0400__2

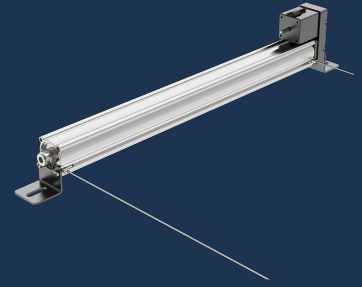
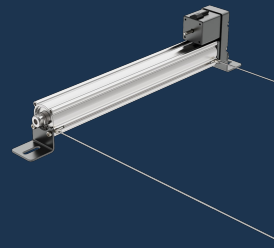
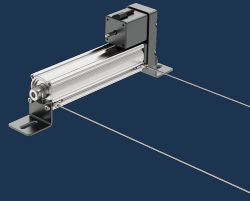

Displacement Ratio (mm/turn)

6

6

6

Stroke Length (mm)

100

250

400

Max Force (N)

255

255

255

Max Speed (mm/s)

200

200

200

Precision (mm)

± 0.02

± 0.02

± 0.02

Assembly Instructions

The electric cylinders come with two sheet metal brackets. These brackets can be attached to Vention extrusions or plates using M8 X 16mm fasteners and T-nuts as required. The end of the electric cylinder push rod is a female M8 X 1.25 thread. It is possible to attach other Vention parts such as the [Pneumatic and Electric Actuator Push Block](#) using the provided M8 X 20 fastener.

The motor cable provided with the electric cylinder has 4 ends: one end that connects to the MachineMotion 2 controller, one end that connects to the motor (already connected out-of-the-box) and 2 ends for the position sensors. Once the actuator is installed:

1. Connect the Sensor A cable end to the sensor closest to the shaft opening.
2. Connect the Sensor B cable end to the sensor furthest away from the shaft opening.
3. Finally connect the motor cable to the MachineMotion 2 controller to begin operation.

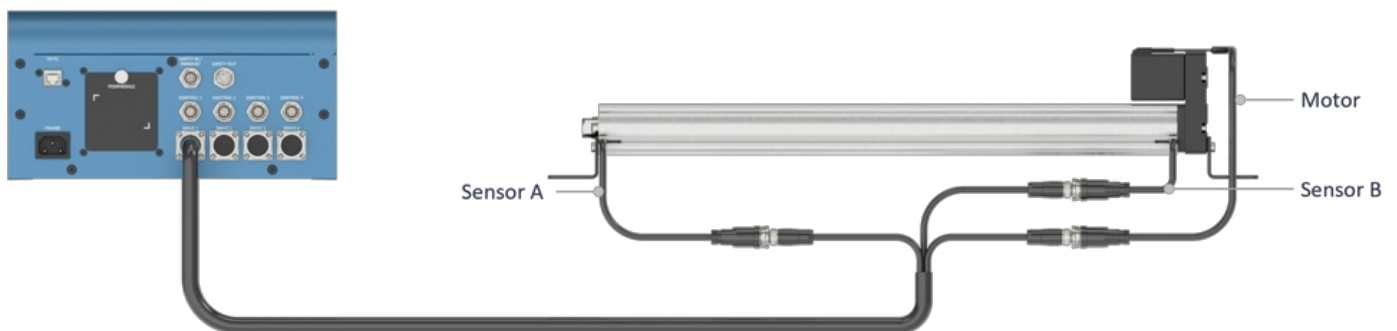

Electric Cylinder wiring with the MachineMotion 2 controller

If one wishes to not use one or both reed switches as position sensors, connect the cable end to one of 2 the provided sensor jumpers CE-JP-000-0000.

Configuration and position sensors setup

Note that the NEMA 17 motor is rated to operate at a maximum of **1.68A** so the associated motor driver should be set to a limit of **1.5A** to ensure motor longevity.

The screenshot shows the VENTION software interface. At the top, there is a navigation bar with icons for Configuration, Network, Manual Control, MachineLogic, App Launcher, and a STOP button. The main content area is divided into two sections: Actuator 1 (Box Pusher) and Drive 4. The Drive 4 configuration is expanded, showing a table with columns for Name, Type, and Motor Size. The 'Custom Current' field is highlighted with a red box and set to 1.5 A. The 'Microsteps' field is set to 8. The 'Default Value: 1.68' is visible below the Custom Current field. There are also checkboxes for 'Gearbox Installed' and 'Brake Installed', and an 'Advanced' dropdown menu.

SW 2.4.0 & HW V2A

Setting the maximum motor current to 1.5A

Also note that the maximum speed the motor can reach without stalling is **200mm/s**.

Actuators



Actuator 1
Drive: 1
Timing Belt without Gearbox



Box Pusher
Drive: 4
Electric Cylinder

Available Control Modules



Digital Inputs/Outputs

Actuator

Max. Speed mm/s

Max. Acceleration mm/s²

Direction Reverse

Endstop Sensors Home (Port B) End (Port A)

Position 0.0 mm

Brake

Move

Jog Increment mm

Absolute Home End

Position Command mm

▶ ■

SW 2.4.0 & HW V2A

Setting the maximum motor speed to 20mm/s

Position sensors can slide along the groove of the electric cylinder and their position can be fixed by tightening the set screw. Sensor A gets triggered when the electric cylinder shaft is fully extended while sensor B gets triggered when fully retracted. Depending on the motor direction, sensors A and B will each correspond to either the Home position or the End position. Motor direction can be configured in the *Configuration* page, inside the *Drive Settings* menu.

Motor direction	Sensor A (shaft fully extended)	Sensor B (shaft fully retracted)
Normal	Home position	End position
Reverse	End position	Home position

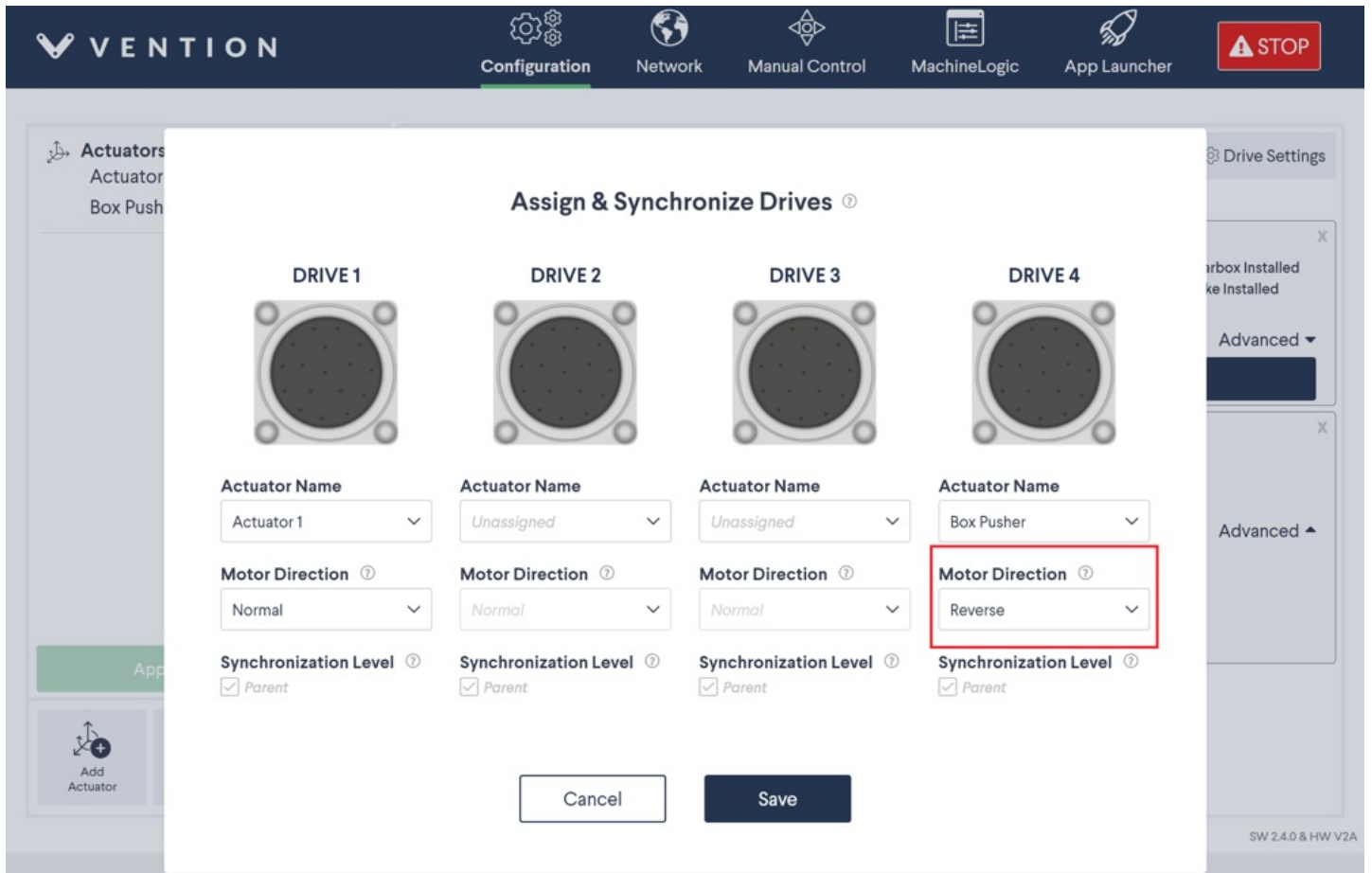

Configuring the motor in reverse direction

Once the motor direction has been chosen and set, follow these steps to set up the position sensors:

1. Fix the sensors in their most extreme positions: sensor A at the end of the electric cylinder closest to the shaft opening, sensor B at the other end furthest away from the shaft opening.
2. Jog the electric cylinder actuator so that the shaft is fully extended (the motor should be heard stalling).
3. Slide sensor A away from the shaft opening. When the red indicator LED turns off, fix the position of the sensor.
4. Jog the electric cylinder actuator so that the shaft is fully retracted (the motor should be heard stalling).
5. Slide sensor B towards the shaft opening. When the red indicator LED turns off, fix the position of the sensor.
6. Jog the electric cylinder actuator back and forth between the Home and End position and make sure the actuator stops when the corresponding sensor gets triggered.