

# Safety Enclosure Ecosystem

## Contents

[Overview](#)

[Applications](#)

[Safety](#)

[Mechanical Testing](#)

[Installation and Assembly](#)

[Machine Guarding Panels \(ST-  
PN-002-0700/1000/1200\)](#)

[Panel Assembly](#)

[Panel Specifications](#)

[Enclosure Doors](#)

[Floor Anchors \(ST-SE-001-0005\)](#)

[Alternate Anchoring](#)

[Configuration for Reduced  
Safety Distance](#)

[Two Way Door Connector](#)

[Safety Interlock and Gate Bolt  
\(ST-SE-006-XXXX\)](#)

[Interlock Specifications](#)

[Safety Interlock Switch \(CE-SA-  
010-0000\)](#)

[Interlock - Pin-out - M12,  
female, 12-pin, A-Keyed, with  
adapter](#)

[Interlock - Pin-out - M12,  
female, 4-pin, A-Keyed,  
without adapter](#)

[Spring Loaded Grab Catch](#)

[Emergency Stop Switch \(CE-SA-  
007-0000\)](#)

[Switch - Pin-out - M12,  
female, 12-pin, A-Keyed](#)

[Wiring Diagram](#)

## Overview

Vention's safety enclosure ecosystem features all the necessary components to quickly deploy a complete safety fencing system or robot cell that integrates directly with the MachineMotion's safety rated input. In this technical document the following will be covered: safety panels, doors, anchoring, interlocks and safety.

## Applications

The typical applications include enclosures for robot cells and automation equipment. The enclosure is used to contain the risk and prevent workers from entering a high risk zone. Take a look at Vention's public designs for some inspiration.

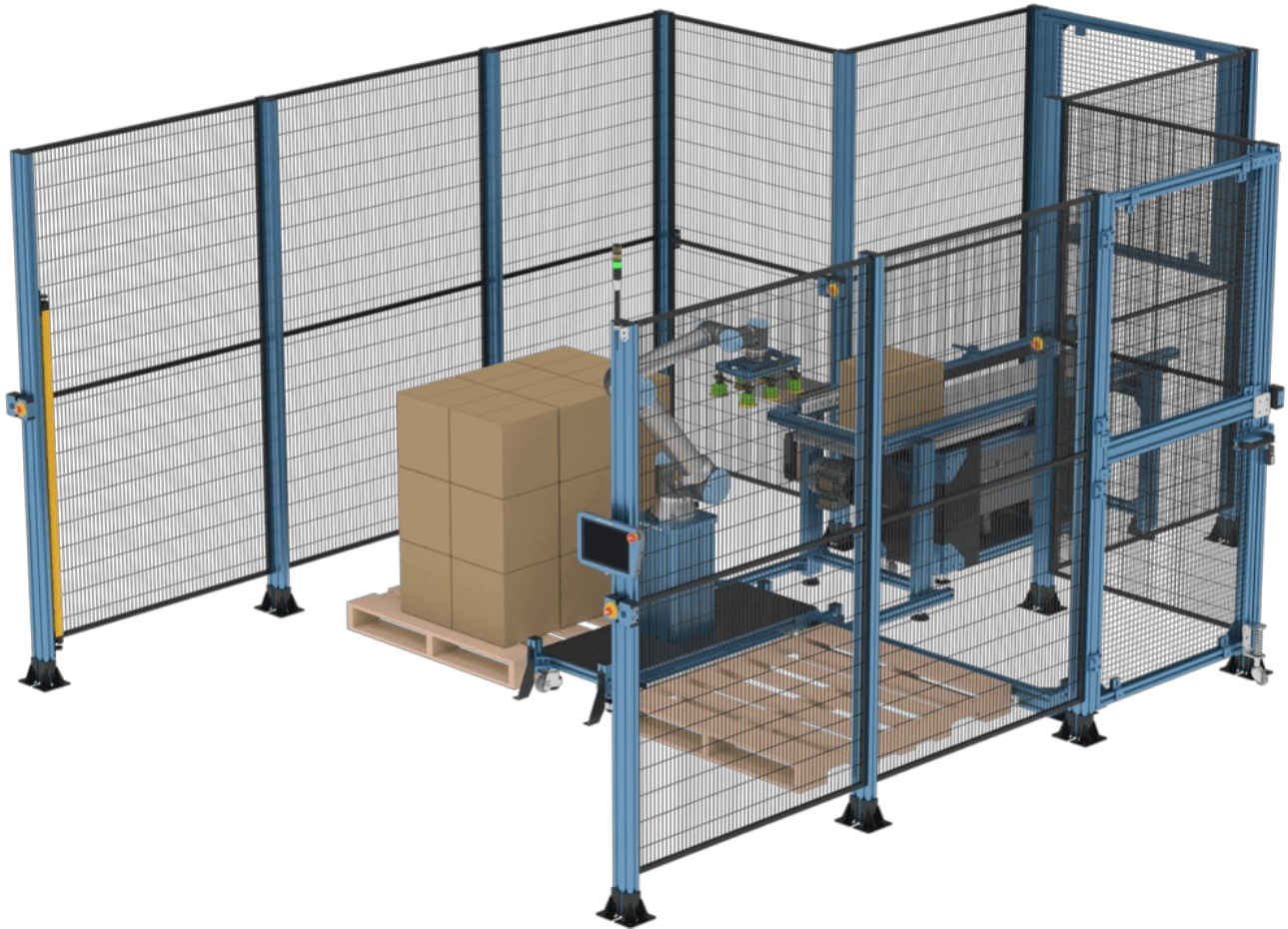

*Cobot Palletizer Cell*

[Browse Open Source Designs](#)

## Safety

### Mechanical Testing

Our current enclosure hardware offerings have been validated to contain impact energies typically seen of industrial robots with a payload of 50kg or less. The machine guarding panels, doors and anchors seen below have been tested in accordance with:

**ISO 14120**, Safety of machinery – Guards - General requirements for the design and construction of fixed and movable guards

Which defines the pendulum test method for mechanically testing the guards.

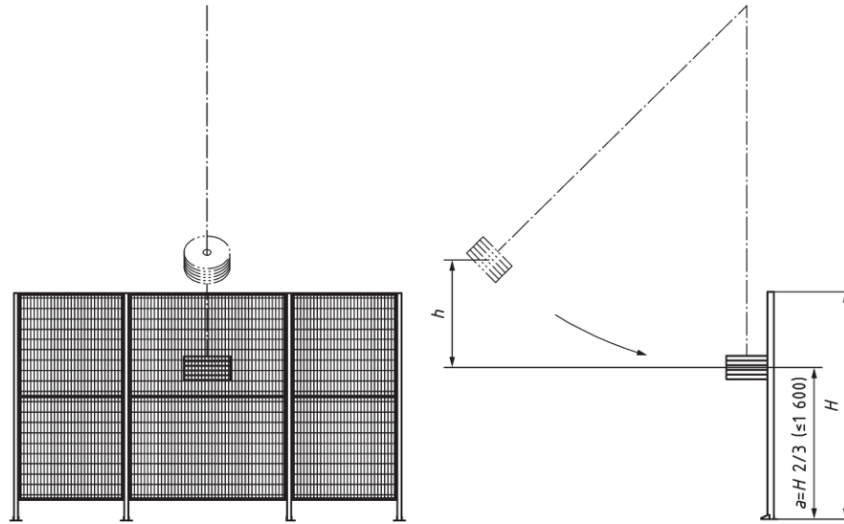

- $H$  guard height
- $h$  falling down height
- $a$  height of point of impact, which shall not be higher than 1 600 mm

**Pendulum test as specified in ISO 14120**

This test was performed in our R&D center with the following inputs:

Input Parameters	
Test Materials	2050 x 1000mm machine guarding panel (ST-PN-002-0700/1000/1200), wire mesh panels (ST-PN-002-0004/0005) held in place using panel retainers (ST-PN-007-0001), 45 x 90mm extrusions supporting columns (ST-EXT-002-2205), welded steel anchors (ST-SE-001-0005), personnel access door, <i>pallet bay access door</i> , safety interlock (ST-SE-006-XXXX)
Floor fixing	Four 3/8" x 4" expansion anchors per supporting column
Guard height (H)	2205 mm
Falling height (h)	1700 mm
Impact height (a)	1470 mm
Pendulum mass	45 kg
Impact speed	5.5 m/s
Impact energy	750 J

**\*Refer to MachineBuilder designs for full product definition and BOM**

The test is considered a pass if it respects the following conditions as defined by ISO 14120:

- The deformations or cracks do not exceed values specified to avoid harm,
- There is no penetration,
- The guard window or infill material is not loosened from its fixing, and
- The guard is not loosened from its guard support

All tests conducted successfully withstood the high energy impact. The center of the panels and posts absorbed all energy and sustained plastic deformation. Total deflection was that whereby no penetration or removal of parts occurred.



*Post-impact deformation of machine guarding panel*

## Installation and Assembly

The safety enclosures shall be installed according to the assembly instructions and according to the requirements of:

**ISO 13857**, Safety of machinery – Safety distances to prevent hazard zones being reached by upper and lower limbs, and

**ISO 13855**, Safety of machinery – Positioning of safeguards with respect to the approach speeds of parts of the human body.

The safety distance to prevent reaching hazards over the safety enclosure or through its openings is calculated according to the requirements of ISO 13857.

Height of hazard zone <sup>c</sup> <i>a</i>	Height of protective structure <sup>a, b</sup> <i>b</i>									
	1 000	1 200	1 400	1 600	1 800	2 000	2 200	2 400	2 500	2 700
Horizontal safety distance to hazard zone, <i>c</i>										
2 700	0	0	0	0	0	0	0	0	0	0
2 600	900	800	700	600	600	500	400	300	100	0
2 400	1 100	1 000	900	800	700	600	400	300	100	0
2 200	1 300	1 200	1 000	900	800	600	400	300	0	0
2 000	1 400	1 300	1 100	900	800	600	400	0	0	0
1 800	1 500	1 400	1 100	900	800	600	0	0	0	0
1 600	1 500	1 400	1 100	900	800	500	0	0	0	0
1 400	1 500	1 400	1 100	900	800	0	0	0	0	0
1 200	1 500	1 400	1 100	900	700	0	0	0	0	0
1 000	1 500	1 400	1 000	800	0	0	0	0	0	0
800	1 500	1 300	900	600	0	0	0	0	0	0
600	1 400	1 300	800	0	0	0	0	0	0	0
400	1 400	1 200	400	0	0	0	0	0	0	0
200	1 200	900	0	0	0	0	0	0	0	0
0	1 100	500	0	0	0	0	0	0	0	0

*Reach-over distances specified in ISO 13857*

Limitation of movement	Safety distance to hazard zone, $s_r$	Illustration
Limitation of movement only at shoulder and armpit	$\geq 850$	
Arm supported up to elbow	$\geq 550$	
Arm supported up to wrist	$\geq 230$	
Arm and hand supported up to knuckle joint	$\geq 130$	

$A$  range of movement of arm  
 $s_r$  radial safety distance  
<sup>a</sup> This is either the diameter of a round opening, or the side of a square opening, or the narrowest dimension of the slot opening.

**Reach-around distances specified in ISO 13857**

Part of body	Illustration	Opening	Safety distance, $s_r$		
			Slot	Square	Round
Fingerlip		$e \leq 4$	$\geq 2$	$\geq 2$	$\geq 2$
		$4 < e \leq 6$	$\geq 10$	$\geq 5$	$\geq 5$
Finger up to knuckle joint		$6 < e \leq 8$	$\geq 20$	$\geq 15$	$\geq 5$
		$8 < e \leq 10$	$\geq 80$	$\geq 25$	$\geq 20$
		$10 < e \leq 12$	$\geq 100$	$\geq 80$	$\geq 80$
		$12 < e \leq 20$	$\geq 120$	$\geq 120$	$\geq 120$
Hand		$20 < e \leq 30$	$\geq 850^a$	$\geq 120$	$\geq 120$
Arm up to junction with shoulder		$30 < e \leq 40$	$\geq 850$	$\geq 200$	$\geq 120$
		$40 < e \leq 120$	$\geq 850$	$\geq 850$	$\geq 850$

The bold lines within the table delineate that part of the body restricted by the opening size.

<sup>a</sup> If the length of the slot opening is  $\leq 65$  mm, the thumb will act as a stop and the safety distance can be reduced to 200 mm.

**Regular reach-through distances specified in ISO 13857**

Part of lower limb	Illustration	Opening	Safety distance, $s_r$	
			Slot	Square or round
Toe tip		$e \leq 5$	0	0
		$5 < e \leq 15$	$\geq 10$	0
Toe		$15 < e \leq 35$	$\geq 80^a$	$\geq 25$
Foot		$35 < e \leq 60$	$\geq 180$	$\geq 80$
		$60 < e \leq 80$	$\geq 650^b$	$\geq 180$
Leg (toe tip to knee)		$80 < e \leq 95$	$\geq 1\,100^c$	$\geq 650^b$
Leg (toe tip to crotch)		$95 < e \leq 180$	$\geq 1\,100^c$	$\geq 1\,100^c$
		$180 < e \leq 240$	Not admissible	$\geq 1\,100^c$

Reach-through distances for lower limbs specified in ISO 13857

Table 1 — Reaching over the vertical detection zone of electro-sensitive protective equipment

Dimensions in millimetres

Height of hazard zone $a$	Height of upper edge of the detection zone of the electro-sensitive protective equipment $b$											
	900	1 000	1 100	1 200	1 300	1 400	1 600	1 800	2 000	2 200	2 400	2 600
	Additional distance to hazard zone $C_{RO}$											
2 600 <sup>a</sup>	0	0	0	0	0	0	0	0	0	0	0	0
2 500	400	400	350	300	300	300	300	300	250	150	100	0
2 400	550	550	550	500	450	450	400	400	300	250	100	0
2 200	800	750	750	700	650	650	600	550	400	250	0	0
2 000	950	950	850	850	800	750	700	550	400	0	0	0
1 800	1 100	1 100	950	950	850	800	750	550	0	0	0	0
1 600	1 150	1 150	1 100	1 000	900	850	750	450	0	0	0	0
1 400	1 200	1 200	1 100	1 000	900	850	650	0	0	0	0	0
1 200	1 200	1 200	1 100	1 000	850	800	0	0	0	0	0	0
1 000	1 200	1 150	1 050	950	750	700	0	0	0	0	0	0
800	1 150	1 050	950	800	500	450	0	0	0	0	0	0
600	1 050	950	750	550	0	0	0	0	0	0	0	0
400	900	700	0	0	0	0	0	0	0	0	0	0
200	600	0	0	0	0	0	0	0	0	0	0	0
0	0	0	0	0	0	0	0	0	0	0	0	0

When a value of zero is given, the calculation of the minimum distance,  $S$ , should be made in accordance with 6.2 to 6.4.

NOTE 1 Electro-sensitive protective equipment with a height of the  
— upper edge of the detection zone below 900 mm is not included since they do not offer sufficient protection against circumventing or stepping over  
— lower edge of the detection zone above 300 mm in relation to the reference plane does not offer sufficient protection against crawling below.

NOTE 2 The data for this table were researched at a study of the German BG, see [22].

NOTE 3 Most values given in Table 1 are lower in relation to the values of ISO 13857:2008, Tables 1 and 2, since parts of the body cannot support themselves on safeguards in case of reaching over.

<sup>a</sup> Approach to the hazard zone by reaching over is impossible.

Safety distances as specified in ISO 13855

## Machine Guarding Panels (ST-PN-002-0700/1000/1200)

The default safety panels used to create Vention enclosures are constructed with a 19 x 19 mm powder coated steel frame. All horizontal wires are welded into the frame and the vertical wires are welded to the cross tubes, creating a stable and impact resistant panel.

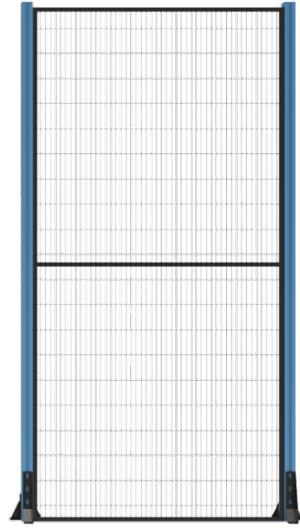
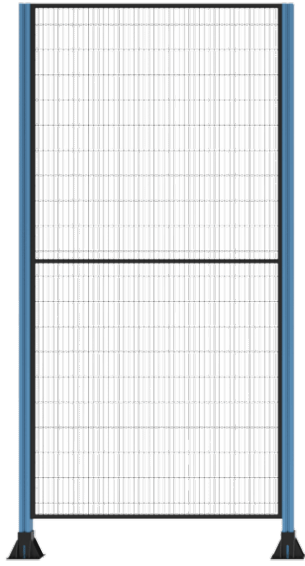

#### *Panel assemblies*

## Panel Assembly

Multiple M8 clearance holes on the vertical panel frame tubes permit easy mounting to the extrusion posts. Each panel will ship with eight M8 x 30mm bolts, washers and t-nuts, as well as six 180mm long segments of t-slot cover. We recommend installing the fasteners on the upper and lower most holes as well as the two center most holes on each side of the panel.

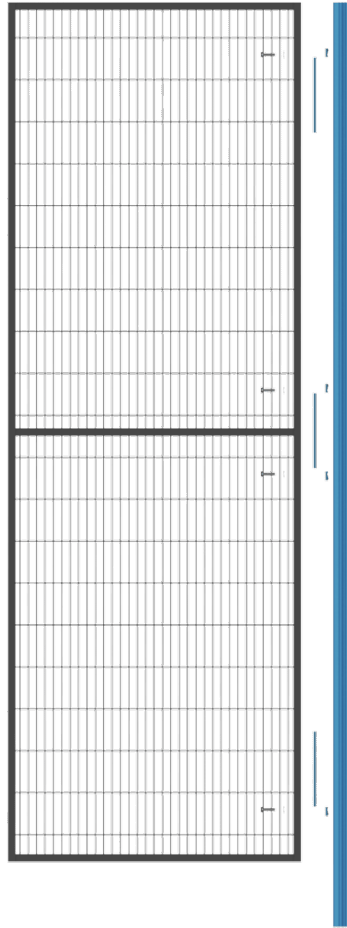

*Panel and post assembly*

The included t-slot covers will serve to square up the panel up against the extrusion when tightened in placed. They are to be installed right next to the t-nut in the case of the upper and lower mounting holes, and in the middle of the two center mounting holes. Not installing the t-slot covers will cause the panel to slip in the the HP feature of the extrusion resulting in the panel not sitting perpendicular to the post when tightened.



*Upper and lower panel mounting*





*Mid-panel mounting*

## Panel Specifications

Height of Panel	2050 mm
Width of Panel	700, 1000, 1200 mm
Mesh Opening	20 x 100 mm
Wire Mesh Diameter	3.12 mm (1/8 in)
Required Extrusion Posts	ST-EXT-002-2205 (45 x 90 x 2205 mm)
Included Hardware per Panel	8x HW-FN-003-0030, 8x HW-FN-002-0001
Allowable Impact Energy	750J

## Enclosure Doors

The entry of your safety enclosure can be constructed by using extrusions to build a door. This main structure can be constructed from 45 x 45 mm light-duty extrusions with an array of assembly plates to hold it all together. One side supported by the Vention Door Hinge (ST-SE-005-0001), allowing for full 180 degree opening. A single simply supported hinge can support up to 600kg in pure shear. A door with 2 hinges can support a moment up to 1000 N·m in bending. The other side of the door can be held closed by the Vention Gate Bolt. Depending on the level of safety required by the safety enclosure, an interlock can also be installed on the door as either part of the Gate Bolt (ST-SE-006-XXXX) or a stand alone Safety Switch (CE-SA-010-0000). To simplify the sizing of the doors, two ready to ship wire mesh panel sizes have been added to the platform to size the door either for pallet bays or personnel/emergency access. The 2 mesh panel sizes are as follows:

- 920 x 965 mm ([ST-PN-002-0004](#))
- 1505 x 965 mm ([ST-PN-002-0005](#))

To retain the mesh panels as well as meet the requirements of the ISO 14120 impact test, six panel retainers ([ST-PN-007-0001](#)) need to be used per panel; with two per horizontal extrusion, and one per vertical extrusion, spaced equally.

For access to the gate bolt release, cutouts can be made and the sharp edges protected with rubber edge trimming ([ST-PN-014-0002](#)).

The renders below may not fully represent a final installation but should give an idea as to the overall assembly for each of the enclosure doors.

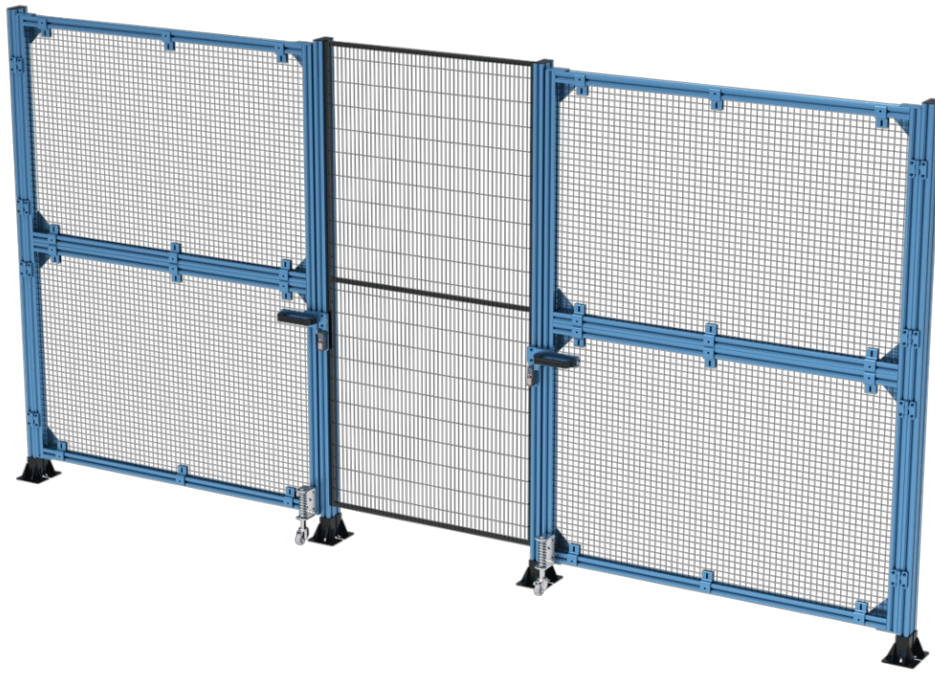

*Pallet Bay Doors*

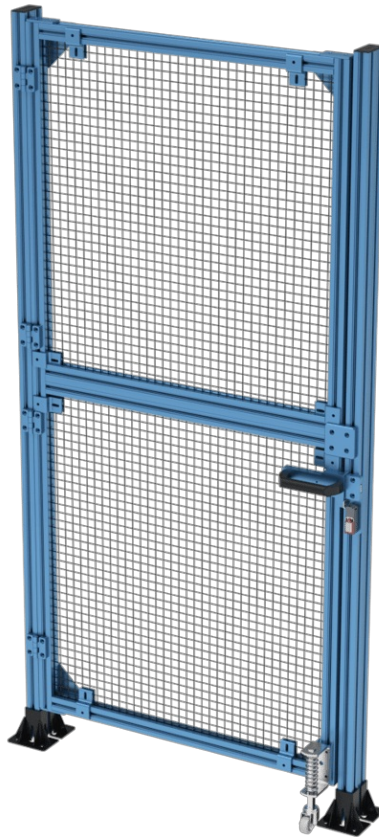

*Personnel/Emergency Access Doors*

## Floor Anchors (ST-SE-001-0005)

Anchors used for machine guarding are vital in ensuring containment of energy. The gusseted design of these anchors will create a lot more stability for loads transferred through the extrusion posts. It can be used with our 45 x 45mm profile but is most rigid mounted in pairs on a 45 x 90mm extrusion profile. Three slots are provided to attach the anchor to the extrusion post with bolts and t-nuts. The slots have been designed in a way for the bolts to be partially pre-threaded into the t-nuts and then to allow the anchor to be slid over them after for easy installation. The anchoring holes on the base plate are clearance-sized for 3/8" diameter anchors.



*Machine guarding anchors*

## Alternate Anchoring Configuration for Reduced Safety Distance

An alternate anchoring configuration has been tested and validated under the same impact energy for use cases where the respected safety distance is less than 650mm. This configuration makes use of the Machine Guarding Floor Anchor (ST-SE-001-0005) on the inner side of the enclosure (the high energy side) and the Leveling Foot Floor Bracket (HW-LF-001-0004) on the outer side of the enclosure. This will permit for the panel to be lowered to less than the 80mm opening required to respect the 650mm safety distance.



*Alternate anchoring configuration*

## Two Way Door Connector

When a Two-Way Extended Door Connector ([ST-GP-004-0006](#)) is used to create a door frame with an interlocking part such as a Spring-Loaded Grab Catch ([HW-LT-002-0001](#)), Gate Bolt ([ST-SE-006-0001\\_2](#)) or Safety Interlock switch ([CE-SA-010-0000](#)) on the edge, stiffeners must be used.

The figure on the left side illustrates an example of a non-rigid door with an interlocking part. The middle figure shows an arrangement of four L-Shaped Aluminum Assembly Plates ([ST-GP-001-0005](#)) that can be mounted in each corner to achieve increased frame stiffness. L-Shaped plates are to be installed **over** the 2-way door connector, however only three bolts will fit, this is correct. Alternatively, as shown on the right side figure, a cross brace can be created by fastening two 45mm x 45mm Door Spacers ([ST-GP-002-0006](#)) on each end of an extrusion which will also increase stiffness.

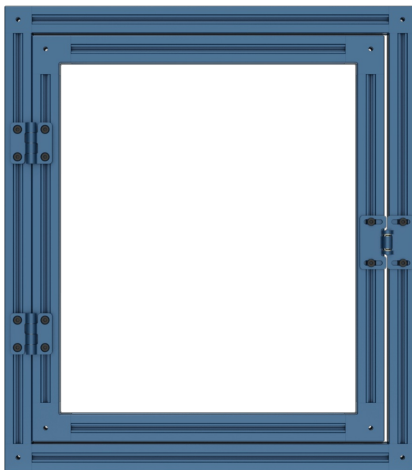

*Non-rigid door with interlocking part*

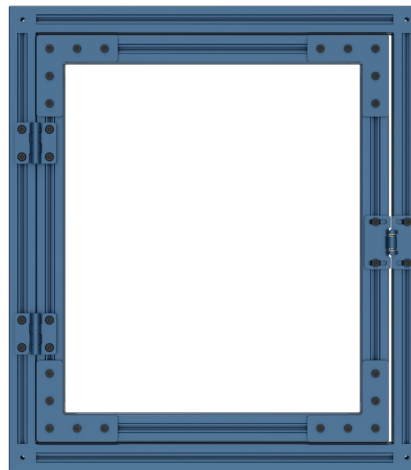

*Four L-Shaped plates*

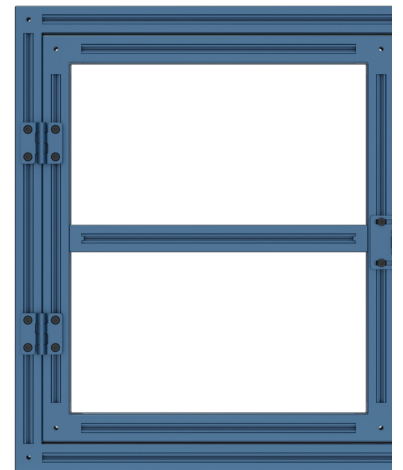

*Cross brace*

## Safety Interlock and Gate Bolt (ST-SE-006-XXXX)

A safety interlock is recommended in order to properly secure your safety enclosure door, when activated it will immediately power off all actuators connected to the MachineMotion controller.

Vention's gate bolt is available with or without a safety interlock tongue and groove system and features an adjustable slide with an anti-vibration system so you don't have to worry about your gate bolt and door unintentionally opening.

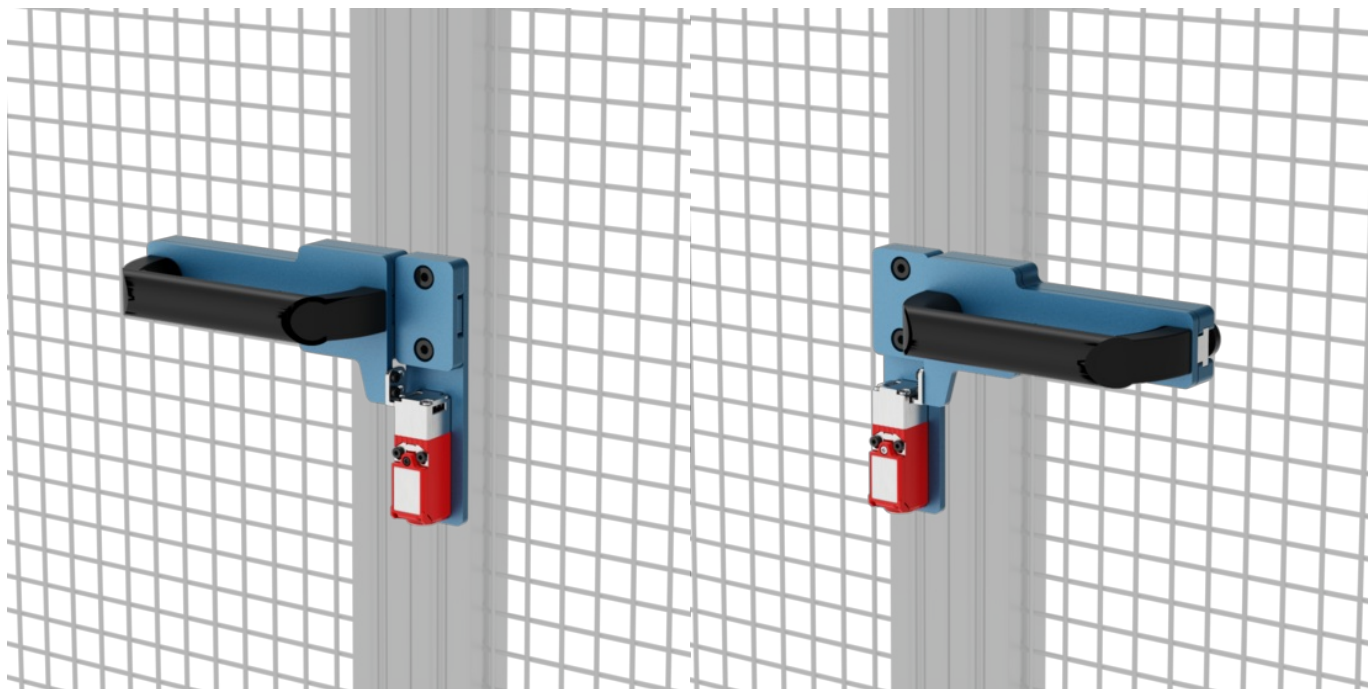

*Right with Interlock*

*Left with Interlock*

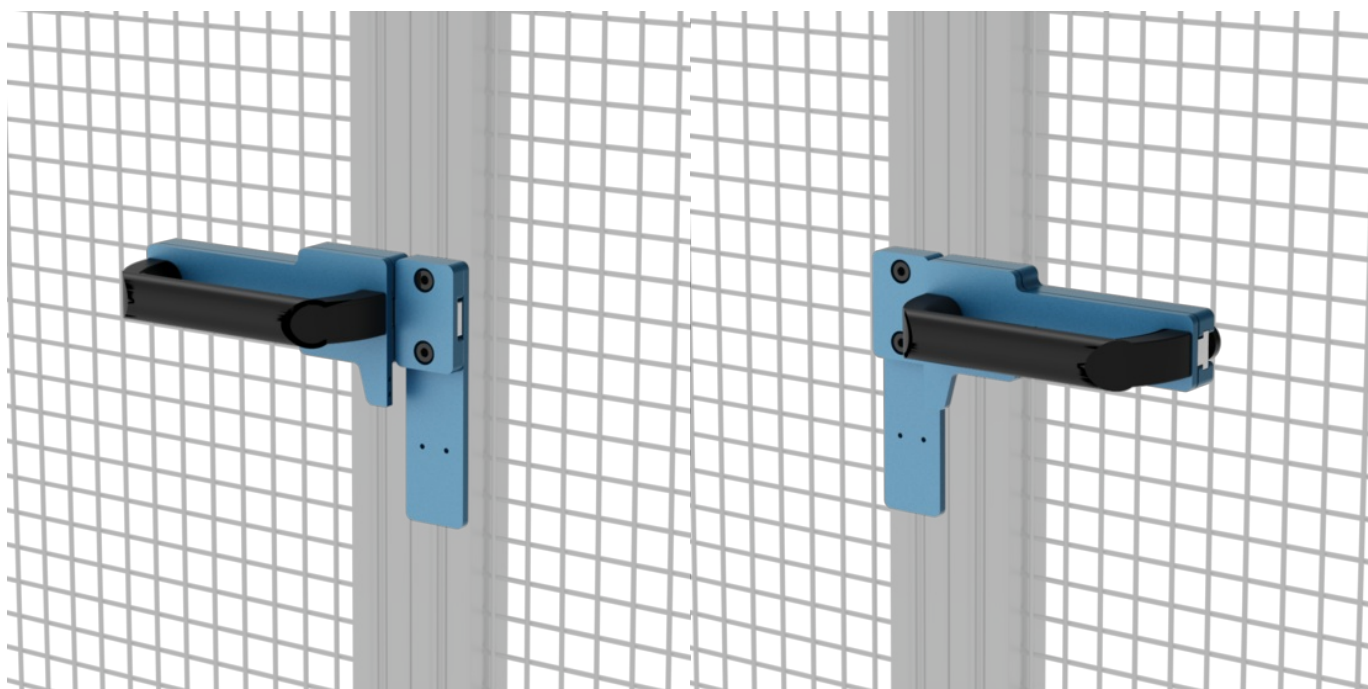

*Right without Interlock*

*Left without Interlock*

The gate bolt comes in four variants, a right ([ST-SE-006-0001](#) [2](#) [ST-SE-006-0011](#) [2](#)) and a left ([ST-SE-006-1001](#) [2](#) or [ST-SE-006-1011](#) [2](#)), with or without an interlock included. Both feature the same allowable door gap and the versions with interlock included have the following specifications. Gate bolts with interlock also include a 5-meter M12 4-Pin extension ([CE-CA-102-5001](#) [2](#)).

Vention's lockable gate bolt and interlock, available in right ([ST-SE-006-2001](#)) and left ([ST-SE-006-2002](#)) configurations shown below, are used in conjunction with Access Request Module ([CE-SA-017-0001](#)) to allow for full deactivation of your industrial robot cell until the gate is properly closed. Lockable gate bolts with interlock also include a 5-meter M12 4-Pin extension ([CE-CA-102-5001](#) [2](#)).

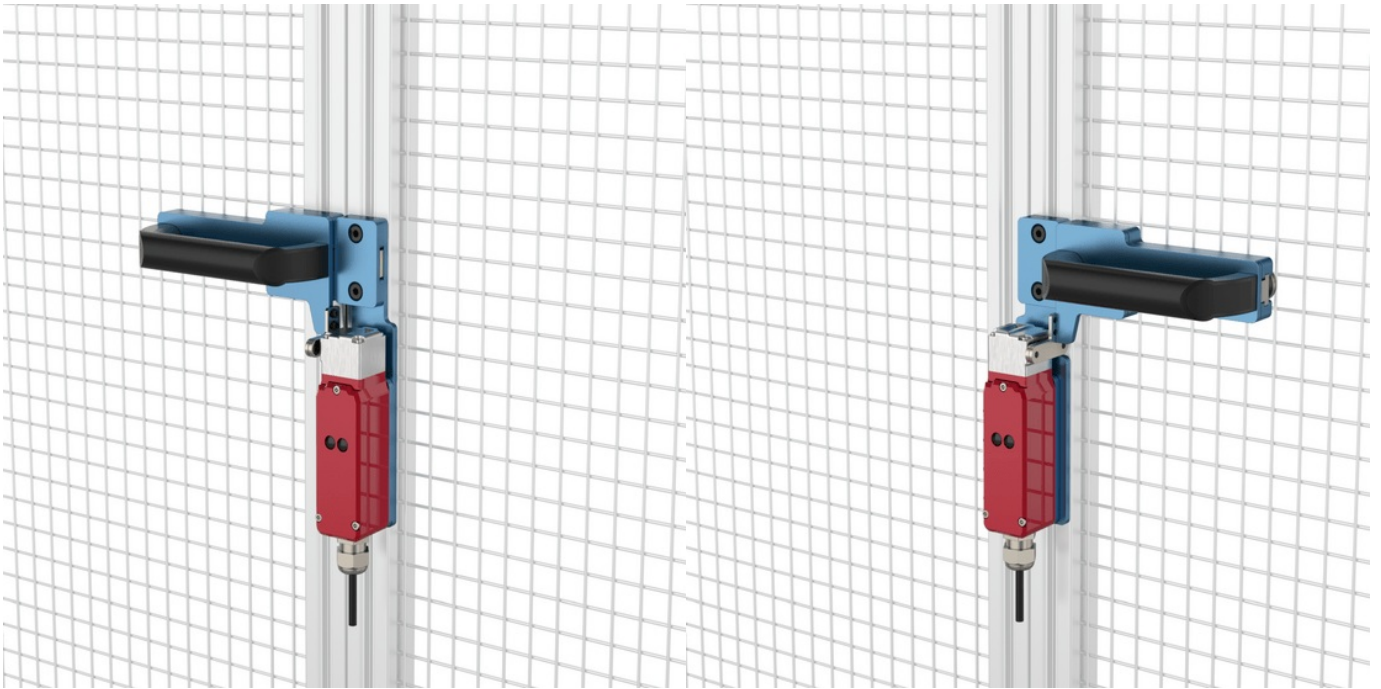

*Right with Lockable Interlock*

*Left with Interlock*

## Interlock Specifications

Allowable Door Gap	0 to 22.5mm
Interlock Contact Configuration	2 N.C. (Normally Closed) Contacts
Interlock Connector	Male M12 4-Pin
Force for Opening [N]	12N



**Note:** A 90x90 Rest Pad ([HW-RP-002-0006](#)) can be used as a door stopper to prevent the gate from swinging inwards.

## Safety Interlock Switch (CE-SA-010-0000)

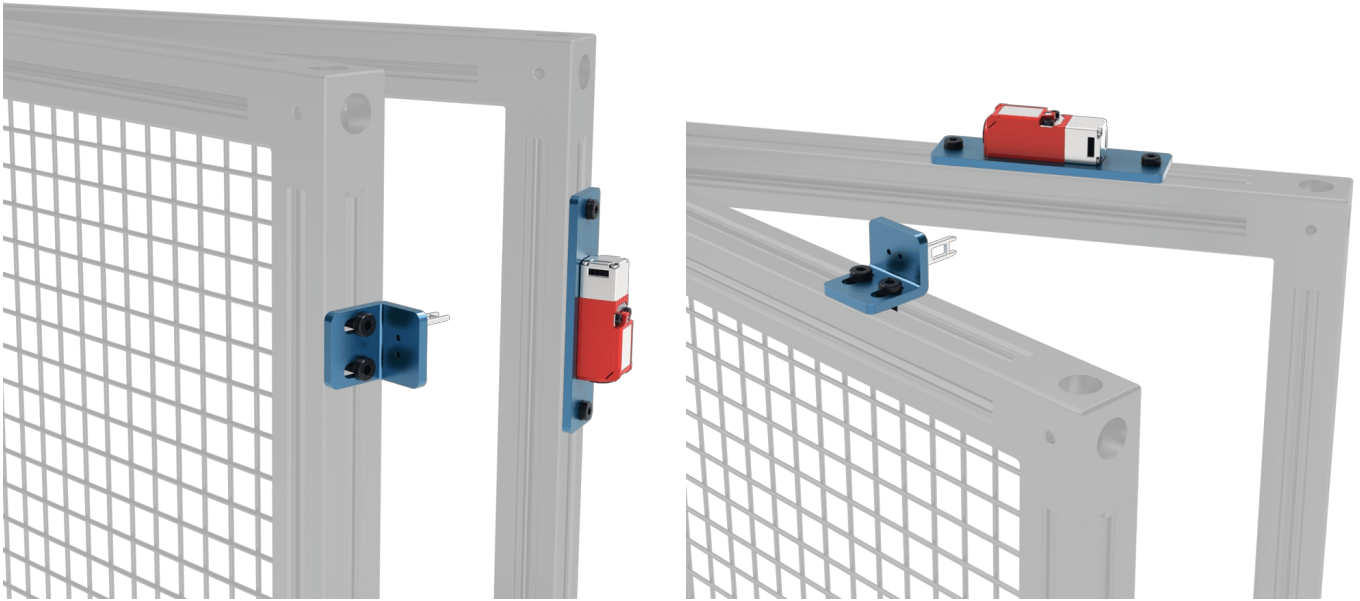

For a door with a 22.5mm gap, a Safety Interlock Switch [CE-SA-010-0000](#) with a door catch can be used as a substitute. The switch and groove mechanism features the same Interlock as the Gate Bolt with identical specifications. A door stopper is included and the entire assembly is fully reversible for left/right opening.

**Note:** When creating a door assembly, the door must be wider than 150mm to allow the tongue to properly enter the interlock.

## Interlock - Pin-out - M12, female, 12-pin, A-Keyed, with adapter



Pin	Description	Color
Pin 3	Channel 1 Contact 1	White
Pin 4	Channel 1 Contact 2	Green
Pin 5	Channel 2 Contact 1	Pink
Pin 6	Channel 2 Contact 2	Yellow

## Interlock - Pin-out - M12, female, 4-pin, A-Keyed, without adapter

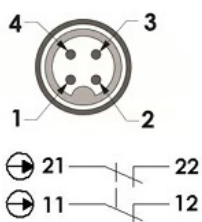

Pin	Description	Color
-----	-------------	-------



Pin	Description	Color
Pin 1	Channel 1 Contact 1	Brown
Pin 2	Channel 2 Contact 2	Blue
Pin 3	Channel 1 Contact 2	White
Pin 4	Channel 2 Contact 1	Black

For any questions about creating a custom Vention assembly for your application contact our application engineers via a design review.

## Spring Loaded Grab Catch

The Vention spring-loaded grab catch (HW-LT-002-0001) can be used in conjunction with the gate bolt, safety interlock or alone. When used with 45mm extrusions, the allowable gap is 0 to 22.5mm. For 22.5mm extrusion doors the allowable gap is 22.5 to 45mm.



**Note:** A rest pad is still required to prevent the gate from swinging inward. Also, place the grab catch close to the door handle otherwise the door will not open or close smoothly.

## Emergency Stop Switch (CE-SA-007-0000)

□

An Emergency Stop Switch is recommended in order to immediately power off all actuators connected to the MachineMotion controller. The Emergency Stop Switch must be connected to the MachineMotion Safety-In port. Multiple emergency stop switches can be connected to a single MachineMotion using the Safety-In and Safety-Out ports on the switch. If only one switch is used the included jumper should be connected to the Safety-In port on the switch.



## Switch - Pin-out - M12, female, 12-pin, A-Keyed

Pin	Description	Color
Pin 3	Channel 1 Contact 1	White
Pin 4	Channel 1 Contact 2	Green
Pin 5	Channel 2 Contact 1	Pink
Pin 6	Channel 2 Contact 2	Yellow
Pin 7	Reset Contact 1	Black
Pin 8	Reset Contact 2	Gray

## Wiring Diagram

The interlock on the Safety Switch ([CE-SA-010-0000](#)) or Safety Gate Bolt ([ST-SE-006-0001\\_2](#) or [ST-SE-006-1001\\_2](#)) comes with a safety wire splitter. The interlock must be connected to the MachineMotion Safety-In port. Multiple interlocks and Emergency Stop Switches can be connected to a single MachineMotion using the wire splitter provided with the interlock or Safety-In and Safety-Out ports on the switch. If only one interlock is used the included jumper must be connected to the unused port.