

Telescopic Lift Column

Contents

[Overview](#)

[Applications](#)

[Cobot palletizers](#)

[Workstations](#)

[8th axis palletizer](#)

[Technical Specifications](#)

[Load Capacity](#)

[Driving Force and Speed](#)

[Duty Cycle](#)

[Specific Robot Compatibility](#)

[Specific Robot Limitations](#)

[Electrical Specifications](#)

[Assembly Instructions](#)

[Maintenance](#)

Overview

The telescopic lift column is a rigid, high force column designed for heavy duty applications. This fully enclosed column has no pinch points and requires minimal maintenance.

The column is guided by high performance plastic plain bearings and the motion assembly is driven by 2 lead screws which are joined together by a belt drive system and Vention's standard 156mm NEMA 34 Stepper Servo Motors. The efficiency of the actuator is tuned to ensure a self-locking system to be completely safe for cobot usage while minimizing friction and energy loss.

The motor, sensors and drive components are all pre-installed inside the lift column, leaving only the mounting of the column to the ground or frame, the robot atop the column, and plugging the column into the controller the only steps to be fully deployed.

The lift column's base extrusion is equipped with T-slots to enable mounting of accessories and controllers, such as MachineMotion or pneumatic controls. **It should be noted that these T-slots are not structural and should not be used for any load bearing applications.**

The telescopic column is only compatible with MachineMotion 2 controllers.

Precise mechanical synchronization of telescopic columns is not possible and they must be used as individual units

The telescopic column is intended for upright operation only. It is not intended to be used horizontally or upside down.

Applications

The Telescopic Lift Column can be used in a variety of applications, offering a simpler design to complex range extenders at higher payloads. The column is designed to support cobots with payloads of up to 25kg including the Doosan H Series, UR Cobots, as well as the Fanuc CRX Series.

Cobot palletizers

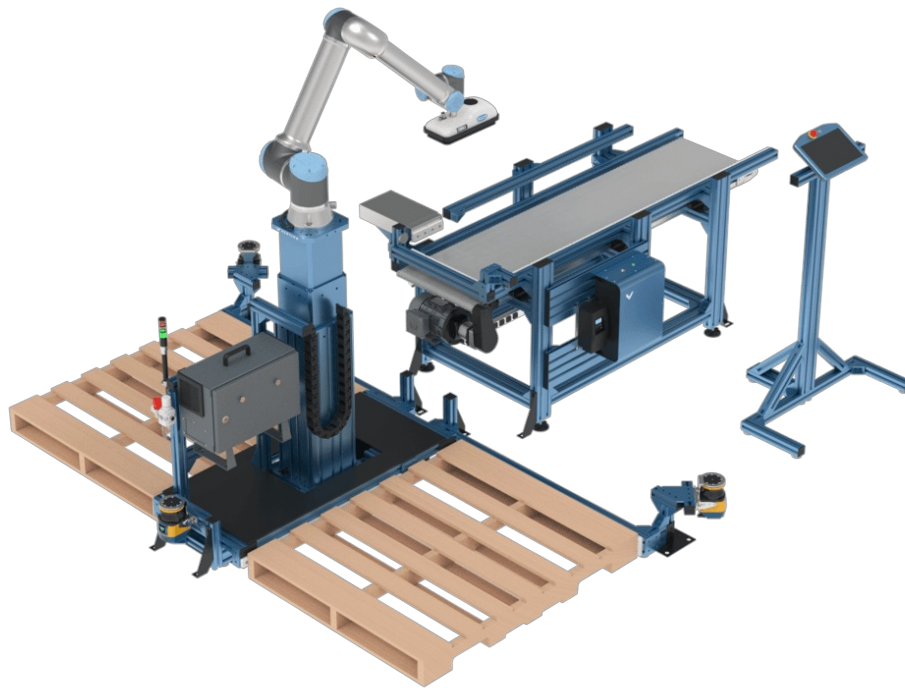

Workstations

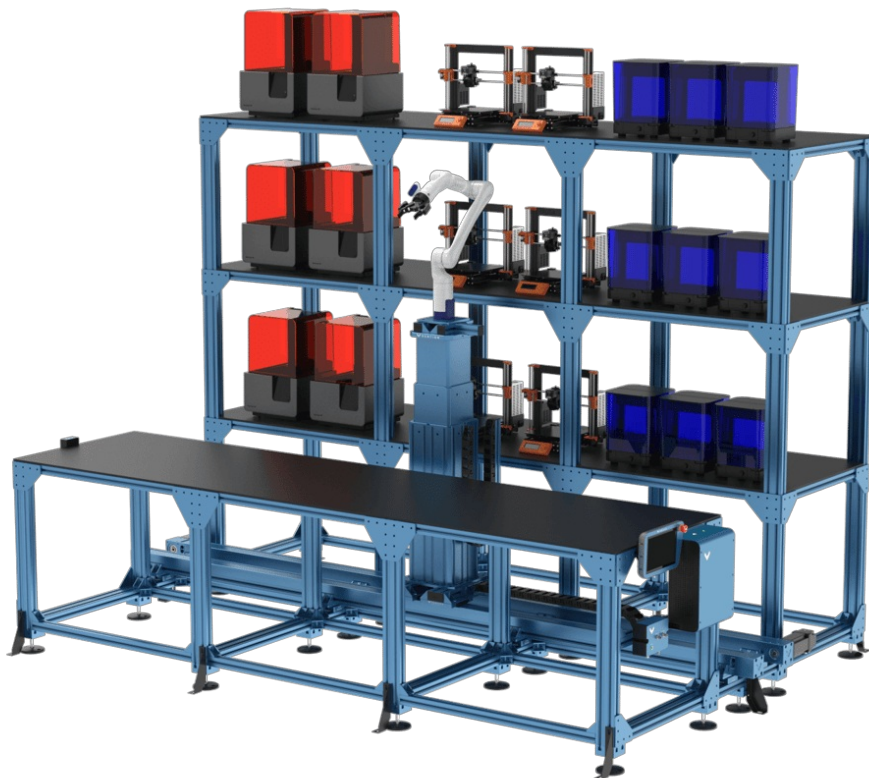

8th axis palletizer

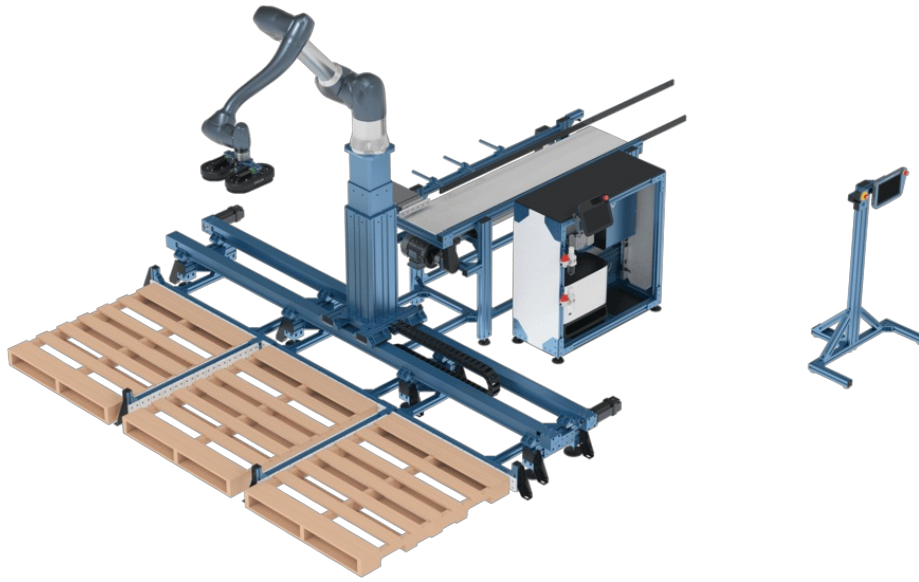

Explore more public designs to get ideas on how you could use the telescopic lift column.

[Browse open-source designs](#)

Technical Specifications

Accuracy from Homed Position	+/- 0.5 mm
Back Drive Resistance	Self Locking
Standard Payload	100 kg
Max Payload*	225 kg
Max Speed (No Payload)	Up to 90 mm/s
Nominal Speed	75 mm/s
Weight	56.54 kg
Footprint	315 mm x 315 mm
Compressed height**	830 mm
Extended height**	1700 mm
Total Travel	870 mm
Displacement ratio	8.38095
Motor Compatibility	Integrated NEMA 34, 14-mm shaft with a 5-mm key
Sensor Compatibility	Integrated sensor: M18 Inductive Proximity Sensor

Note: *Operating at the maximum lifting capacity will reduce the permissible duty cycle.

**The home position and extended position can vary by ± 2 mm among different columns.

Load Capacity

The table and figure below describe the maximum loads and moments in each direction during operation when the column is either stationary or moving. Continued operation at these maximum values will have an impact on product life.

Description	Value
Axial force (F_a)	See Drive Forces
Max Dynamic twist moment (M_t) ***	700 Nm
Max Static twist moment (M_t) ****	1700 Nm
Max Dynamic lateral force (F_l) ***	575 N
Max Static lateral force (F_l) ****	1300 N
Nominal bending moment (M_b)	350 Nm
Max Dynamic bending moment (M_b) ***	700 Nm
Max Static bending moment (M_b) ****	1700 Nm

***Note: Maximum dynamic loads represent the highest loads that can be applied to the top plate of the telescopic lift while motion is still possible. Life will be affected by how often the column is operated at the max bending moment as well as position in stroke. The more extended the lift column is the more stress is applied to the guiding and driving systems, reducing life.

****Note: Maximum static loads represent the highest possible loads applied to the telescopic lift column. At these loads, motion will not be possible and going beyond these values could lead to damage or failure of the lift column. These values must be respected during robot E-stop events.

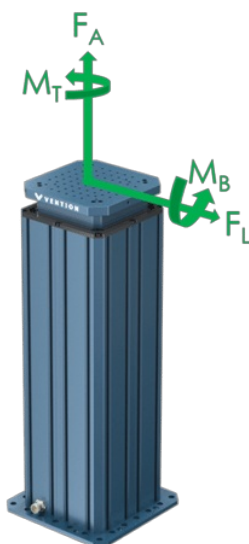

Driving Force and Speed

The driving force indicates how much weight the actuator can move and how quickly it can accelerate. This force is shown as “ F_a ”, or axial force, in the Load Capacity figure. The speed and lifting capacity of the Telescopic Lift Column are dependent on multiple variables with the major two being applied moment and extension position. The speed and lifting capacity of the column decrease as a moment is applied due to added frictional losses between guiding systems. Additionally when a moment is present the extension of the column brings the guiding bearings closer together which increases the friction generated as well.

Note that the graph below represents an idealized situation where **no bending moment** is applied to the column.

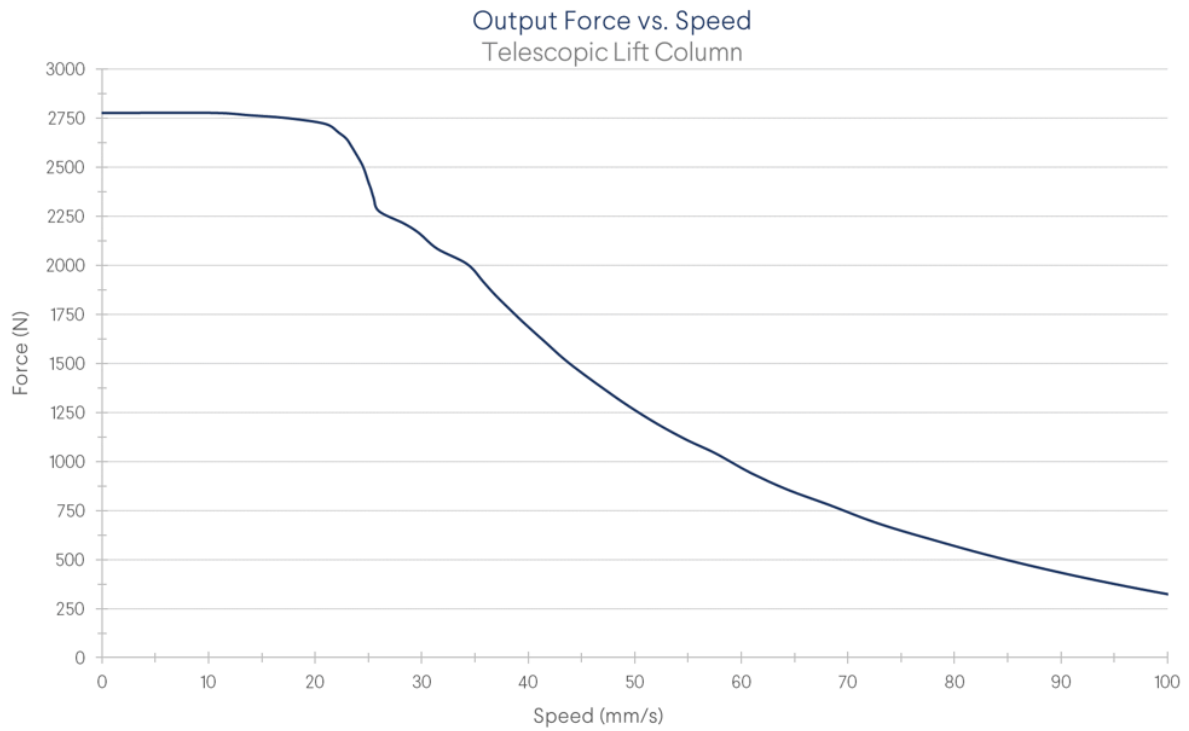

For some examples of more typical applications the following graph shows how the column can be expected to behave depending on different robots and use cases.

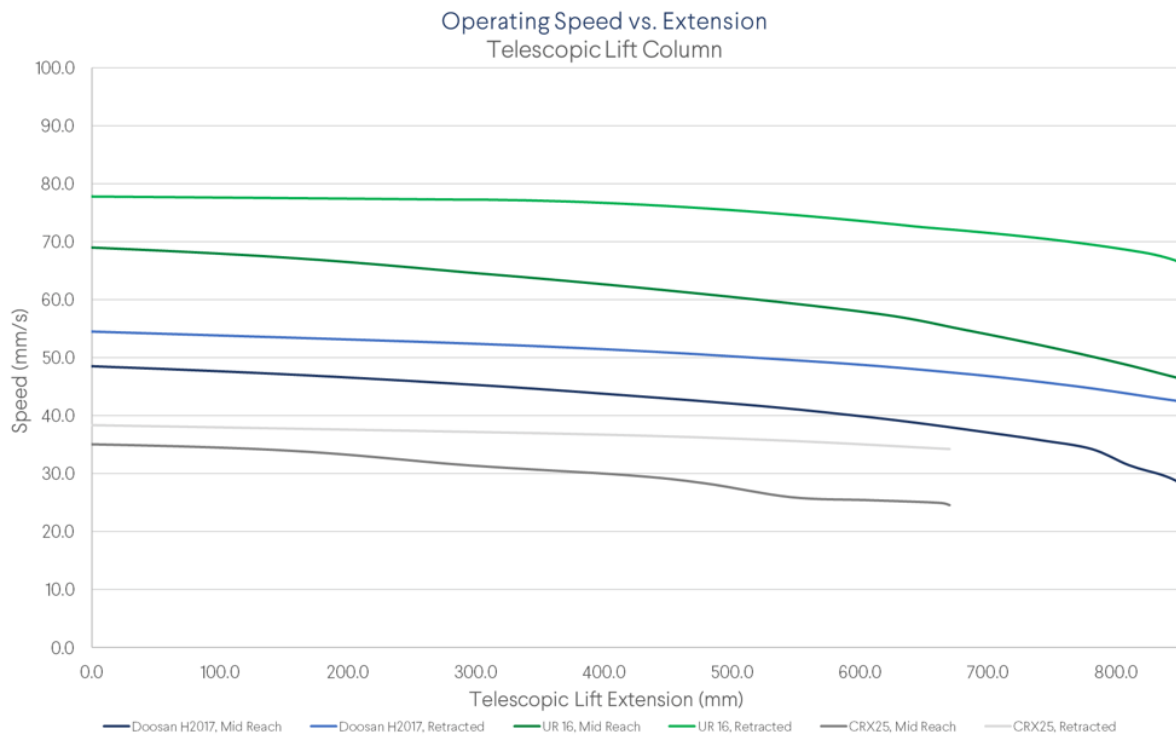

The situations shown in the graph represent the following load cases:

- Doosan H2017 at full payload with an extension that generates a constant 400 Nm bending moment
- Doosan H2017 at full payload at a retracted position such that the bending moment is 200 Nm
- UR 16 at full payload with an extension that generates a constant 285 Nm bending moment
- UR 16 at full payload at a retracted position such that the bending moment is 100 Nm
- CRX25 at full payload with a mid extension that generates a constant 450 Nm bending moment. Note the full stroke of the lift column is not possible with the robot extended.
- CRX25 at full payload at a retracted position such that the bending moment is 250 Nm

For assistance in calculating the expected travel speeds of the lift column for please contact our application engineering specialists.

Duty Cycle

The duty cycle of the telescopic actuator is 10% when being used with a 100kg payload and travel speeds of 40-50mm/s and alternating moment loads from 0 to 700 Nm. The meaning of 10% duty cycle is such that in a 1 hour period the lift column would operate in evenly spaced spurts for a total of 6 minutes within the hour.

Exceeding this 10% duty cycle can cause heat build up and lead to increased wear and reduction in life of components and grease.

Reducing load, moment, and/or speed can increase the duty cycle.

For assistance in knowing if your application will respect the duty cycle or questions about the life of the lift column, please contact our application engineering specialists.

Specific Robot Compatibility

The telescopic lift is designed to natively support the following robots:

- Fanuc
 - CRX-10
 - CRX-20
- Universal Robots
 - UR10e
 - UR16e
- Doosan
 - H2017
 - H2515
 - M0609
 - M0617
 - M1013
 - M1509
- Epson T6

With use of robot plates the list of compatible robots is expanded to include:

- Fanuc
 - CRX-5
- Universal Robots
 - UR3e
 - UR5e
- Aubo
 - i5
 - i10
- Epson
 - G3
 - T3
- Franka Emika Panda
- Mecademic Meca500
- Omron TM5

Specific Robot Limitations

All of the above listed robots are supported by the telescopic lift column. Some robots may have some limitations to ensure compatibility which will be listed below.

In general it is recommended to move the telescopic lift while the robot is retracted or partially retracted. Do not operate the telescopic lift while the robot arm is fully extended.

Electrical Specifications

Below the motor specifications as well as the connector pinout are provided:

Property	Value
----------	-------

Property	Value
Number of phases	2
Number of steps	200
Step angle	1.8°
Rated voltage	2.4VDC
Rated max. current	10A
Phase resistance	0.24Ω ± 0.1 (20°C)
Phase inductance	2.9mH ± 20% (1kHz 1V RMS)

Connector pin number	Wire group/gauge	Wire color	Function
1	Signal/24AWG	White	Incremental encoder Z+ output (5V TTL)
2	Signal/24AWG	Yellow	Incremental encoder B- output (5V TTL)
3	Signal/24AWG	Green	Incremental encoder B+ output (5V TTL)
4	Signal/24AWG	Pink	Incremental encoder A- output (5V TTL)
5	Signal/24AWG	Gray	Incremental encoder A+ output (5V TTL)
6	Motor/18AWG	Black	Stepper Phase B- input
7	Motor/18AWG	Blue	Stepper Phase B+ input
8	Motor/18AWG	White	Stepper Phase A- input
9	Motor/18AWG	Brown	Stepper Phase A+ input
10	Auxiliary/24AWG	Blue	0V input (100mA)
11	Auxiliary/24AWG	Brown	24V input (100mA)
12	Signal/24AWG	Purple	Incremental encoder Z- output (5V TTL)
13	Signal/24AWG	Blue	End Sensor B output (24V normally closed)
14	Signal/24AWG	Black	End Sensor A output (24V normally closed)
15	Signal/24AWG	Orange	Reserved/Do not connect
16	Signal/24AWG	Red	Reserved/Do not connect
17	Auxiliary/24AWG	Black	Brake input (24V unlocked, 750mA)

Assembly Instructions

The telescopic lift column comes completely pre-assembled, with its integrated motor and sensors. All you need to do is connect it to a MachineMotion 2 controller. The telescopic column can be mounted in one of two ways:

1. Directly to the floor using our floor anchoring solution. For instructions and requirements see [ST-RB-033-0002](#).
2. Use a Vention frame and/or plate with appropriate ballast. Contact our application engineers for help determining the required ballast for your application. The base of the telescopic column should be attached to the extrusion frame or ballast using the twelve included M8 X 1.25 X 18mm fasteners torqued to 13-15Nm.

To attach a drag chain to the telescopic lift column, use MO-DC-002-1485 and follow these instructions:

- Detach the first 5 links from the rest of the drag chain.

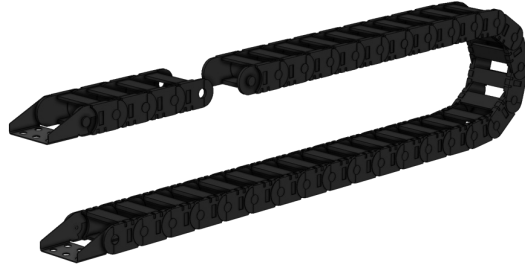

- Flip the section of 5 links upside down so that they bend in the opposite direction as the rest of the chain.

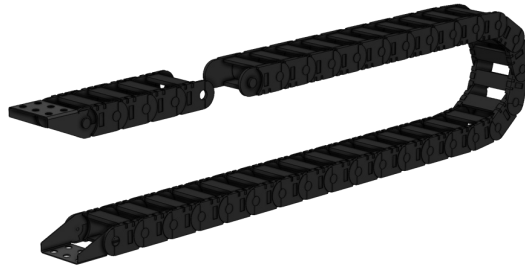

- The drag chain end must also be flipped so that it is in the same orientation as the unmodified end.

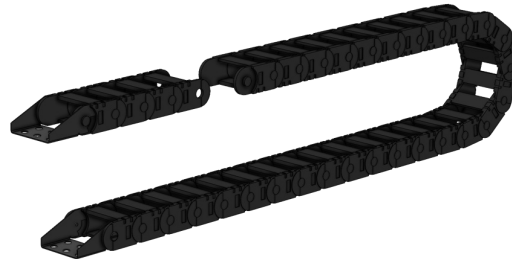

- Reattach the 5 links to the rest of the drag chain. The chain should now be able to be arranged into the following shape.



- Attach the drag chain to the telescopic lift column by screwing the end with the modified links to the telescopic lift top plate. The unmodified side of the drag chain should be connected to the top third of the main extrusion of the telescopic lift column.



The top plate of the telescopic lift column has holes for mounting the drag chain on two sides. If you wish to install the drag chain on another side, simply remove the top plate by undoing the eight M6 fasteners and rotate the plate by 90 degrees. Reinstall the telescopic lift top plate and attach the drag chain to the side of your choice.

Maintenance

For maintenance instructions please refer to the appropriate section in our [Maintenance Technical Document](#).